

XPT IGBT

$$V_{CES} = 1200V$$

$$I_{C25} = 88A$$

$$V_{CE(sat)} = 1.8V$$

Copack

Part number

IXA60IF1200NA



Backside: isolated

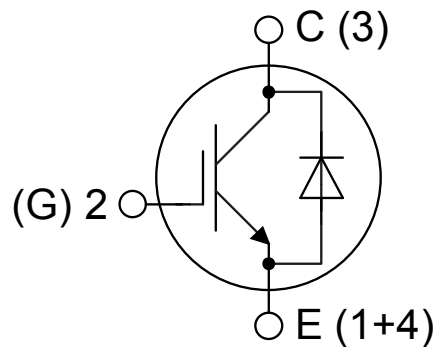
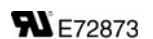

Features / Advantages:

- Easy paralleling due to the positive temperature coefficient of the on-state voltage
- Rugged XPT design (Xtreme light Punch Through) results in:
 - short circuit rated for 10 μ sec.
 - very low gate charge
 - low EMI
 - square RBSOA @ 3x I_c
- Thin wafer technology combined with the XPT design results in a competitive low $V_{CE(sat)}$
- SONIC™ diode
 - fast and soft reverse recovery
 - low operating forward voltage

Applications:

- AC motor drives
- Solar inverter
- Medical equipment
- Uninterruptible power supply
- Air-conditioning systems
- Welding equipment
- Switched-mode and resonant-mode power supplies
- Inductive heating, cookers
- Pumps, Fans

Package: SOT-227B (minibloc)

- Isolation Voltage: 3000 V~
- Industry standard outline
- RoHS compliant
- Epoxy meets UL 94V-0
- Base plate: Copper internally DCB isolated
- Advanced power cycling
- Either emitter terminal can be used as main or Kelvin emitter

| IGBT | | | | Ratings | | | |
|---------------|--------------------------------------|--|-------------------------|---------|----------|---------|----|
| Symbol | Definition | Conditions | min. | typ. | max. | Unit | |
| V_{CES} | collector emitter voltage | $T_{VJ} = 25^{\circ}C$ | | | 1200 | V | |
| V_{GES} | max. DC gate voltage | | | | ± 20 | V | |
| V_{GEM} | max. transient gate emitter voltage | | | | ± 30 | V | |
| I_{C25} | collector current | $T_C = 25^{\circ}C$ | | | 88 | A | |
| I_{C80} | | $T_C = 80^{\circ}C$ | | | 56 | A | |
| P_{tot} | total power dissipation | $T_C = 25^{\circ}C$ | | | 290 | W | |
| $V_{CE(sat)}$ | collector emitter saturation voltage | $I_C = 50A; V_{GE} = 15V$ | | 1.8 | 2.1 | V | |
| | | | | 2.1 | | V | |
| $V_{GE(th)}$ | gate emitter threshold voltage | $I_C = 2mA; V_{GE} = V_{CE}$ | 5.4 | 5.9 | 6.5 | V | |
| I_{CES} | collector emitter leakage current | $V_{CE} = V_{CES}; V_{GE} = 0V$ | | | 0.1 | mA | |
| | | | | 0.1 | | mA | |
| I_{GES} | gate emitter leakage current | $V_{GE} = \pm 20V$ | | | 500 | nA | |
| $Q_{G(on)}$ | total gate charge | $V_{CE} = 600V; V_{GE} = 15V; I_C = 50A$ | | 190 | | nC | |
| $t_{d(on)}$ | turn-on delay time | inductive load $V_{CE} = 600V; I_C = 50A$ $V_{GE} = \pm 15V; R_G = 15\Omega$ | | 70 | | ns | |
| t_r | current rise time | | $T_{VJ} = 125^{\circ}C$ | | 40 | | ns |
| $t_{d(off)}$ | turn-off delay time | | | | 250 | | ns |
| t_f | current fall time | | | | 100 | | ns |
| E_{on} | turn-on energy per pulse | | | | 4.5 | | mJ |
| E_{off} | turn-off energy per pulse | | | | 5.5 | | mJ |
| RBSOA | reverse bias safe operating area | $V_{GE} = \pm 15V; R_G = 15\Omega$ | | | | | |
| I_{CM} | | $V_{CEmax} = 1200V$ | | | 150 | A | |
| SCSOA | short circuit safe operating area | $V_{CEmax} = 1200V$ | | | | | |
| t_{sc} | short circuit duration | $V_{CE} = 900V; V_{GE} = \pm 15V$ | | | 10 | μs | |
| I_{sc} | short circuit current | $R_G = 15\Omega; \text{non-repetitive}$ | | 200 | | A | |
| R_{thJC} | thermal resistance junction to case | | | | 0.43 | K/W | |
| R_{thCH} | thermal resistance case to heatsink | | | 0.10 | | K/W | |
| Diode | | | | | | | |
| V_{RRM} | max. repetitive reverse voltage | $T_{VJ} = 25^{\circ}C$ | | | 1200 | V | |
| I_{F25} | forward current | $T_C = 25^{\circ}C$ | | | 85 | A | |
| I_{F80} | | $T_C = 80^{\circ}C$ | | | 51 | A | |
| V_F | forward voltage | $I_F = 60A$ | | | 2.20 | V | |
| | | | | 1.95 | | V | |
| I_R | reverse current | $V_R = V_{RRM}$ | | | * | mA | |
| | * not applicable, see Ices at IGBT | | | | * | mA | |
| Q_{rr} | reverse recovery charge | $V_R = 600V$ $-di_F/dt = E+03 A/\mu s$ $I_F = 60A; V_{GE} = 0V$ | | 8 | | μC | |
| I_{RM} | max. reverse recovery current | | $T_{VJ} = 125^{\circ}C$ | | 60 | | A |
| t_{rr} | reverse recovery time | | | | 350 | | ns |
| E_{rec} | reverse recovery energy | | | | 2.5 | | mJ |
| R_{thJC} | thermal resistance junction to case | | | | 0.6 | K/W | |
| R_{thCH} | thermal resistance case to heatsink | | | 0.10 | | K/W | |

| Package SOT-227B (minibloc) | | Ratings | | | | |
|-----------------------------|--|----------------------------|-------------------------------------|------|------|------|
| Symbol | Definition | Conditions | min. | typ. | max. | Unit |
| I_{RMS} | RMS current | per terminal ¹⁾ | | | 150 | A |
| T_{VJ} | virtual junction temperature | | -40 | | 150 | °C |
| T_{op} | operation temperature | | -40 | | 125 | °C |
| T_{stg} | storage temperature | | -40 | | 150 | °C |
| Weight | | | | 30 | | g |
| M_D | mounting torque | | 1.1 | | 1.5 | Nm |
| M_T | terminal torque | | 1.1 | | 1.5 | Nm |
| $d_{Spp/App}$ | creepage distance on surface striking distance through air | terminal to terminal | 10.5 | 3.2 | | mm |
| $d_{Spb/Apb}$ | | terminal to backside | 8.6 | 6.8 | | mm |
| V_{ISOL} | isolation voltage | t = 1 second | | | 3000 | V |
| | | t = 1 minute | 50/60 Hz, RMS; $I_{ISOL} \leq 1$ mA | | 2500 | V |

¹⁾ I_{RMS} is typically limited by the pin-to-chip resistance (1); or by the current capability of the chip (2). In case of (1) and a product with multiple pins for one chip-potential, the current capability can be increased by connecting the pins as one contact.

Product Marking

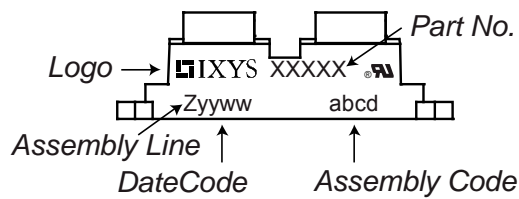

Part description

- I = IGBT
- X = XPT IGBT
- A = Gen 1 / std
- 60 = Current Rating [A]
- IF = Copack
- 1200 = Reverse Voltage [V]
- NA = SOT-227B (minibloc)

| Ordering | Ordering Number | Marking on Product | Delivery Mode | Quantity | Code No. |
|----------|-----------------|--------------------|---------------|----------|----------|
| Standard | IXA60IF1200NA | IXA60IF1200NA | Tube | 10 | 508765 |

| Similar Part | Package | Voltage class |
|--------------|---------------------|---------------|
| IXA70I1200NA | SOT-227B (minibloc) | 1200 |

Equivalent Circuits for Simulation

* on die level

$T_{VJ} = 150$ °C

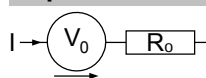

| | IGBT | Diode | |
|--------------|------|-------|----|
| $V_{0\ max}$ | 1.1 | 1.25 | V |
| $R_{0\ max}$ | 28 | 14.2 | mΩ |

Outlines SOT-227B (minibloc)

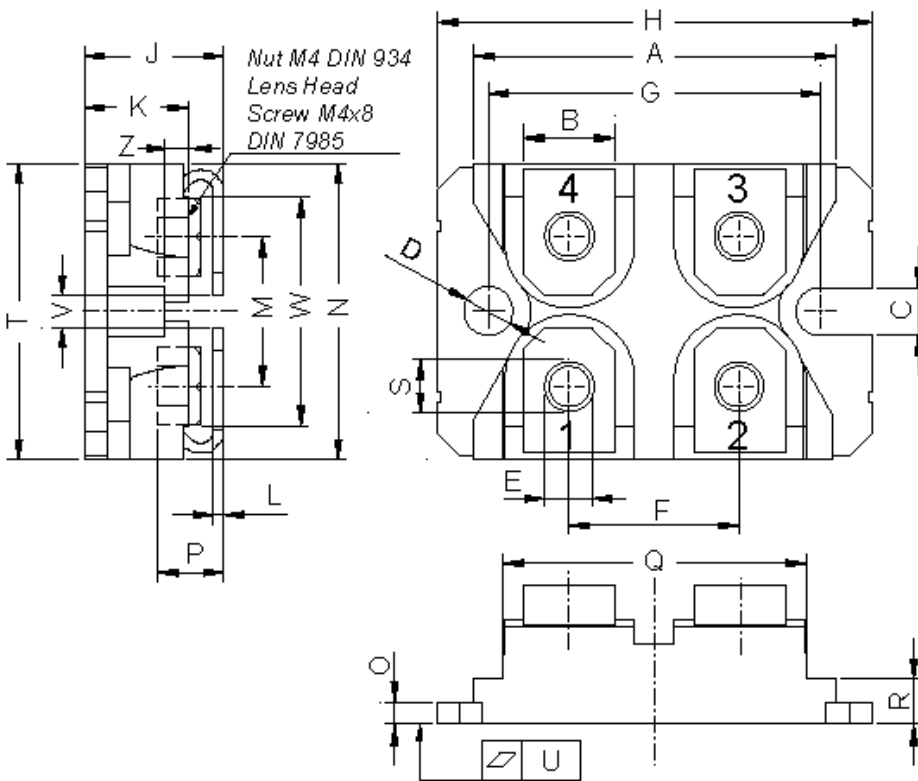

| Dim. | Millimeter | | Inches | |
|------|------------|-------|--------|-------|
| | min | max | min | max |
| A | 31.50 | 31.88 | 1.240 | 1.255 |
| B | 7.80 | 8.20 | 0.307 | 0.323 |
| C | 4.09 | 4.29 | 0.161 | 0.169 |
| D | 4.09 | 4.29 | 0.161 | 0.169 |
| E | 4.09 | 4.29 | 0.161 | 0.169 |
| F | 14.91 | 15.11 | 0.587 | 0.595 |
| G | 30.12 | 30.30 | 1.186 | 1.193 |
| H | 37.80 | 38.23 | 1.488 | 1.505 |
| J | 11.68 | 12.22 | 0.460 | 0.481 |
| K | 8.92 | 9.60 | 0.351 | 0.378 |
| L | 0.74 | 0.84 | 0.029 | 0.033 |
| M | 12.50 | 13.10 | 0.492 | 0.516 |
| N | 25.15 | 25.42 | 0.990 | 1.001 |
| O | 1.95 | 2.13 | 0.077 | 0.084 |
| P | 4.95 | 6.20 | 0.195 | 0.244 |
| Q | 26.54 | 26.90 | 1.045 | 1.059 |
| R | 3.94 | 4.42 | 0.155 | 0.167 |
| S | 4.55 | 4.85 | 0.179 | 0.191 |
| T | 24.59 | 25.25 | 0.968 | 0.994 |
| U | -0.05 | 0.10 | -0.002 | 0.004 |
| V | 3.20 | 5.50 | 0.126 | 0.217 |
| W | 19.81 | 21.08 | 0.780 | 0.830 |
| Z | 2.50 | 2.70 | 0.098 | 0.106 |

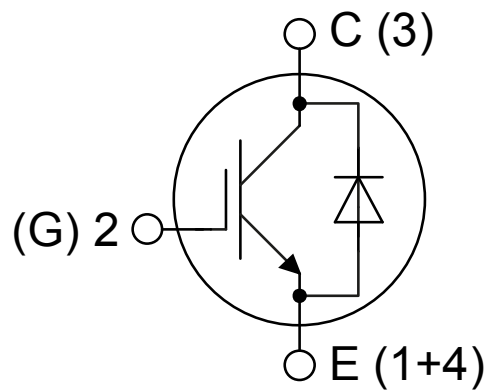

IGBT

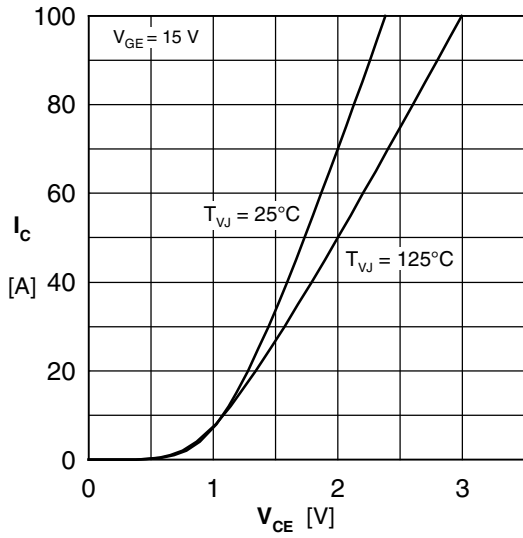

Fig. 1 Typ. output characteristics

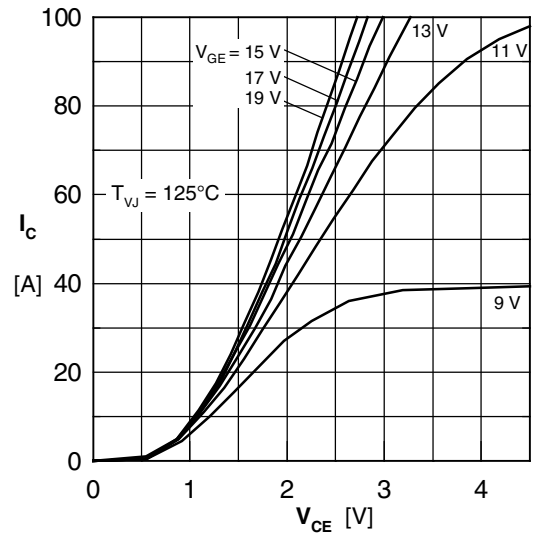

Fig. 2 Typ. output characteristics

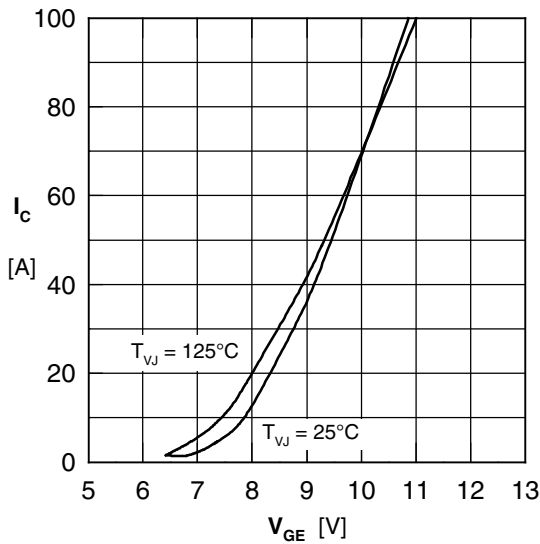

Fig. 3 Typ. transfer characteristics

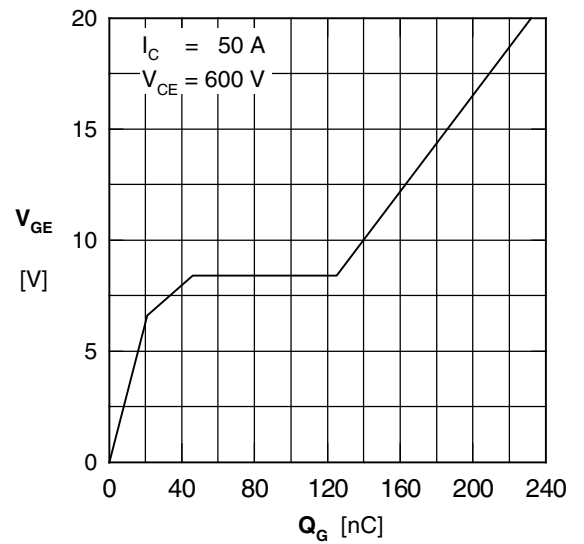

Fig. 4 Typ. turn-on gate charge

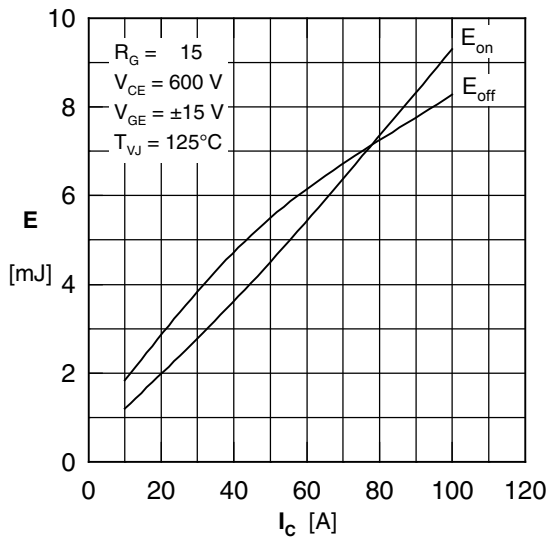

Fig. 5 Typ. switching energy vs. collector current

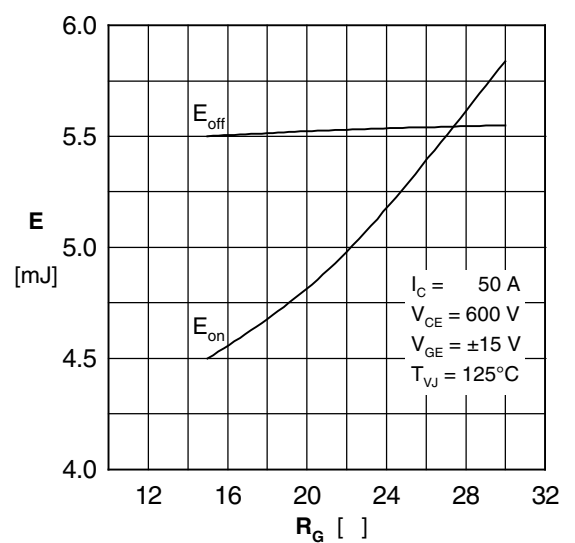

Fig. 6 Typ. switching energy vs. gate resistance

Diode

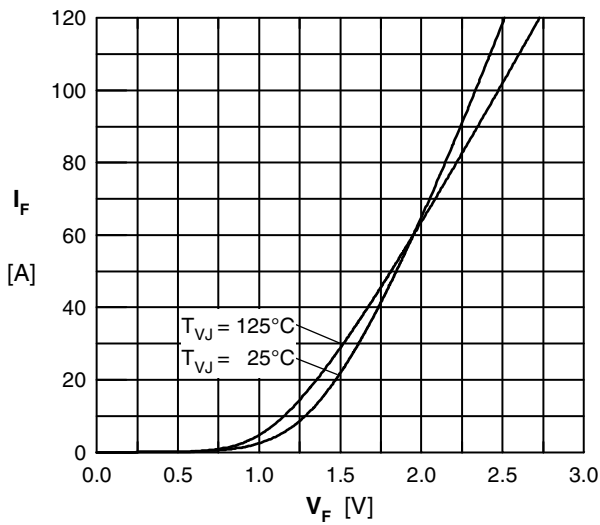

Fig. 7 Typ. Forward current versus V_F

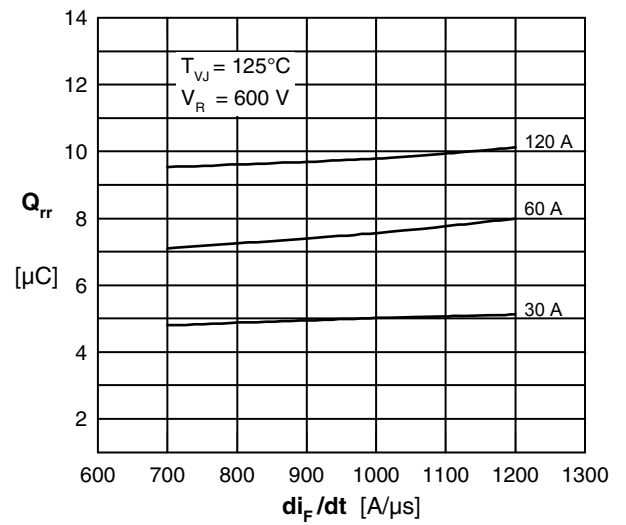

Fig. 8 Typ. reverse recov. charge Q_{rr} vs. di/dt

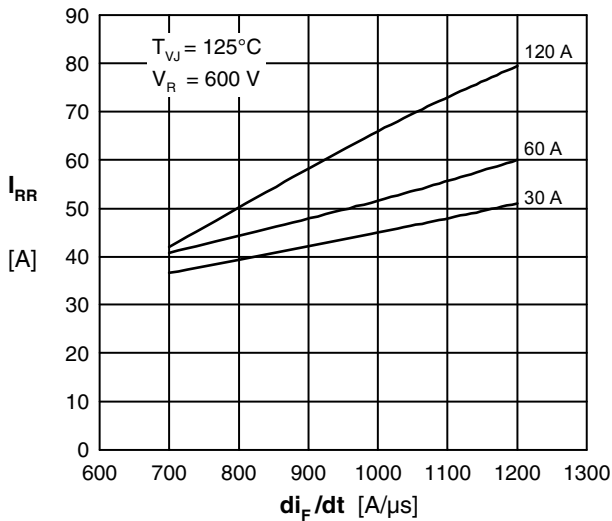

Fig. 9 Typ. peak reverse current I_{RM} vs. di/dt

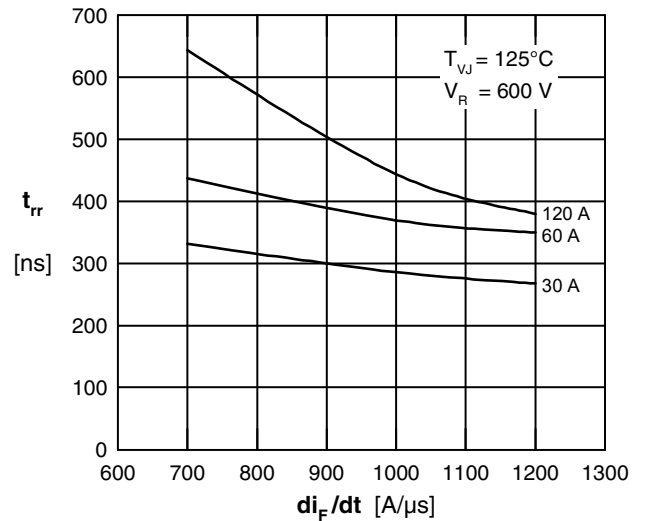

Fig. 10 Typ. recovery time t_{rr} versus di/dt

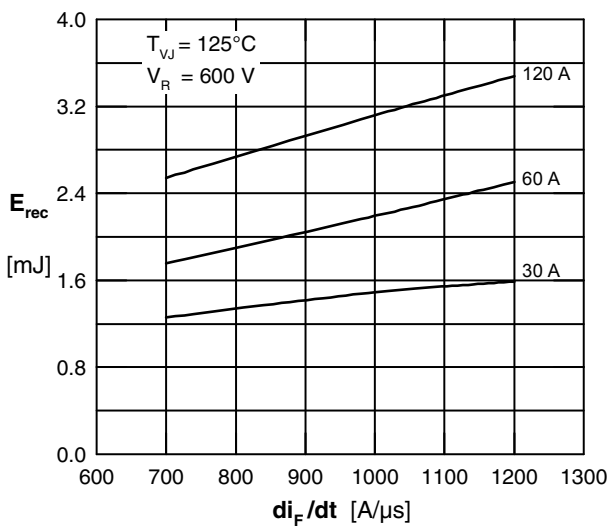

Fig. 11 Typ. recovery energy E_{rec} versus di/dt

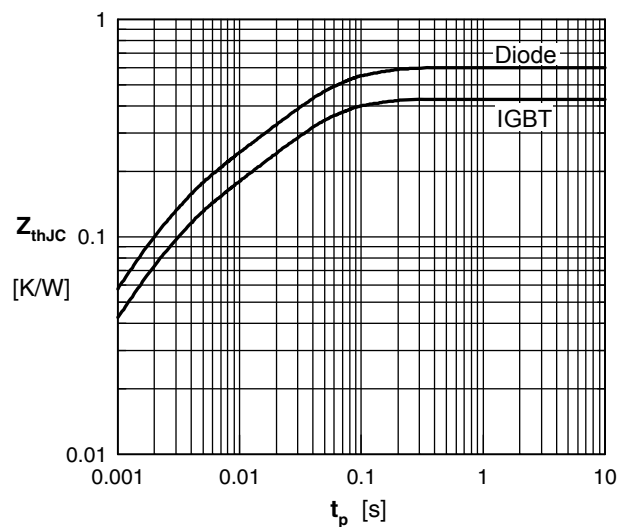

Fig. 12 Typ. transient thermal impedance

Mouser Electronics

Authorized Distributor

Click to View Pricing, Inventory, Delivery & Lifecycle Information:

[IXYS:](#)

[IXA60IF1200NA](#)